

**PEAK HOUR VOLUME**  
**AM: 487**  
**PM: 607**

- LEGEND**
- EXISTING CURB
  - PROPOSED CURB
  - PROPOSED WHITE STRIPING
  - PROPOSED YELLOW STRIPING
  - GREEN BIKE PAINT
  - 42" CHANNELIZER

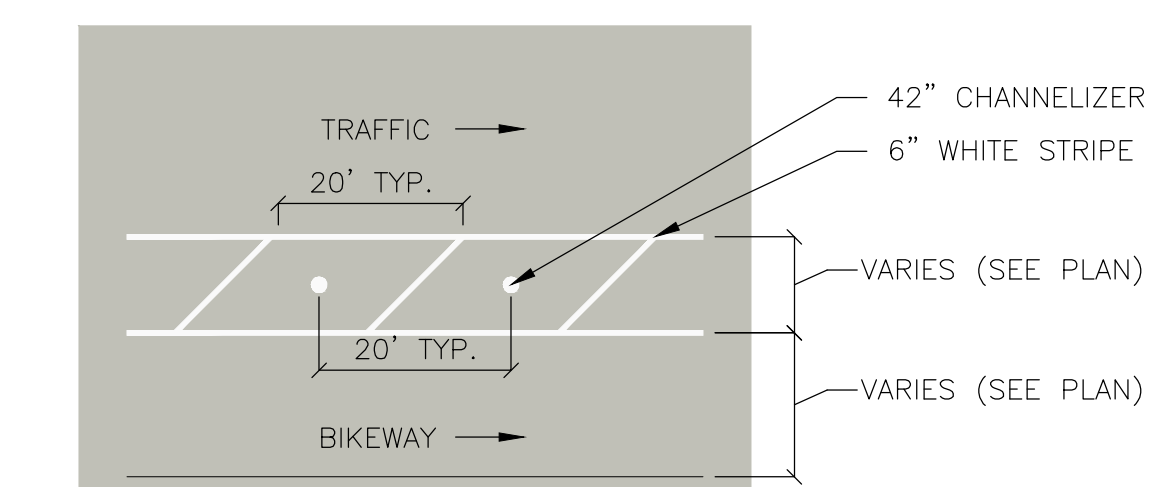

**PROTECTED BIKEWAY DETAIL**  
 N.T.S.

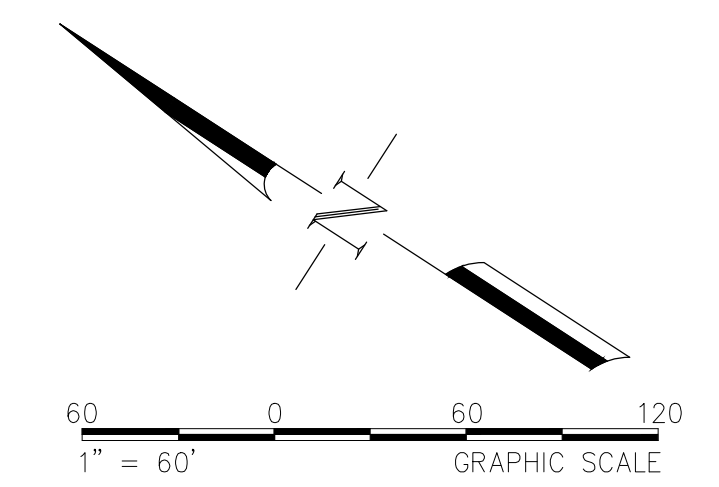

CONCEPTUAL - NOT FOR CONSTRUCTION  
 DETAILED ANALYSIS AND ENGINEERING DESIGN REQUIRED

Figure 1  
**Hopyard Road and I-580**

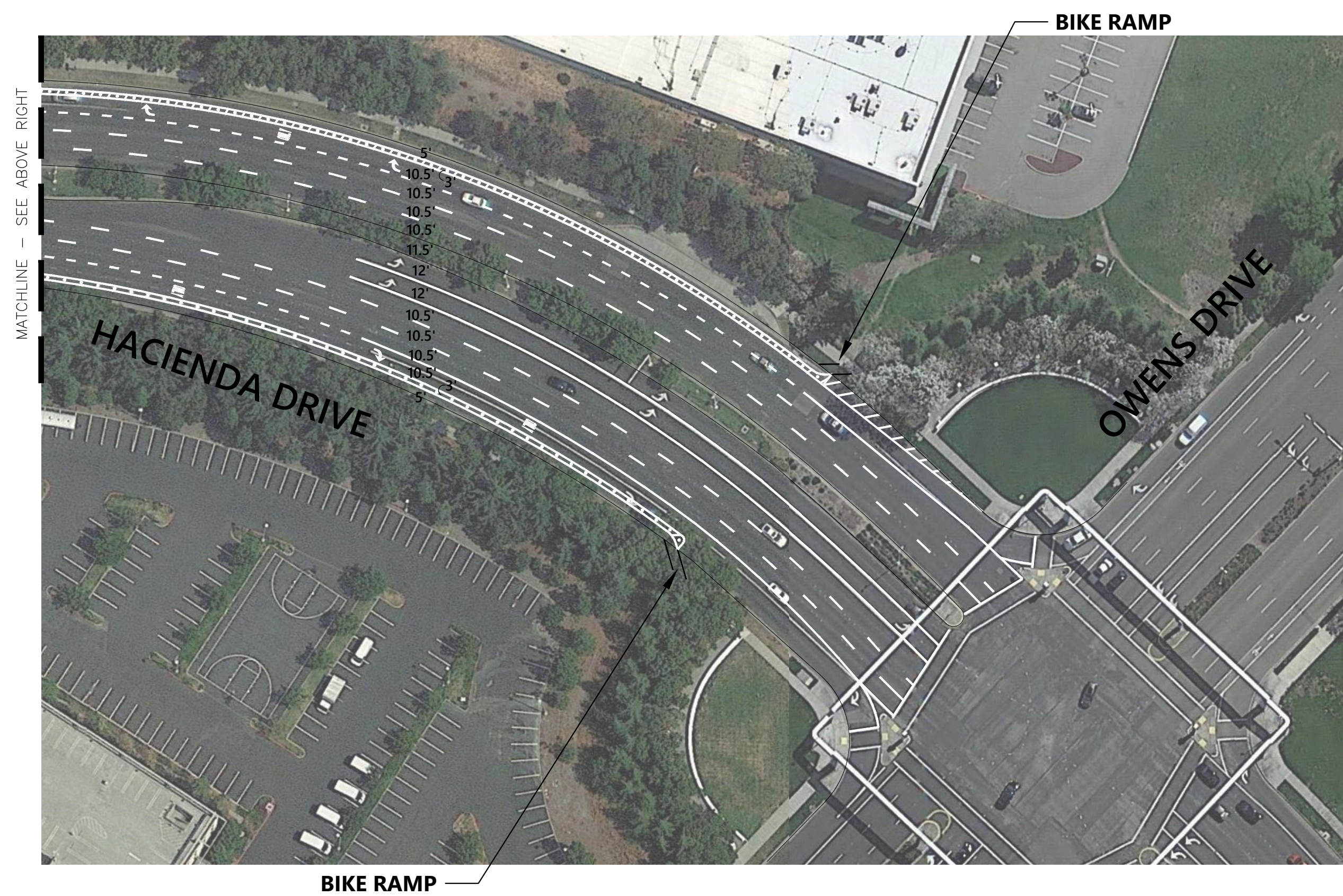
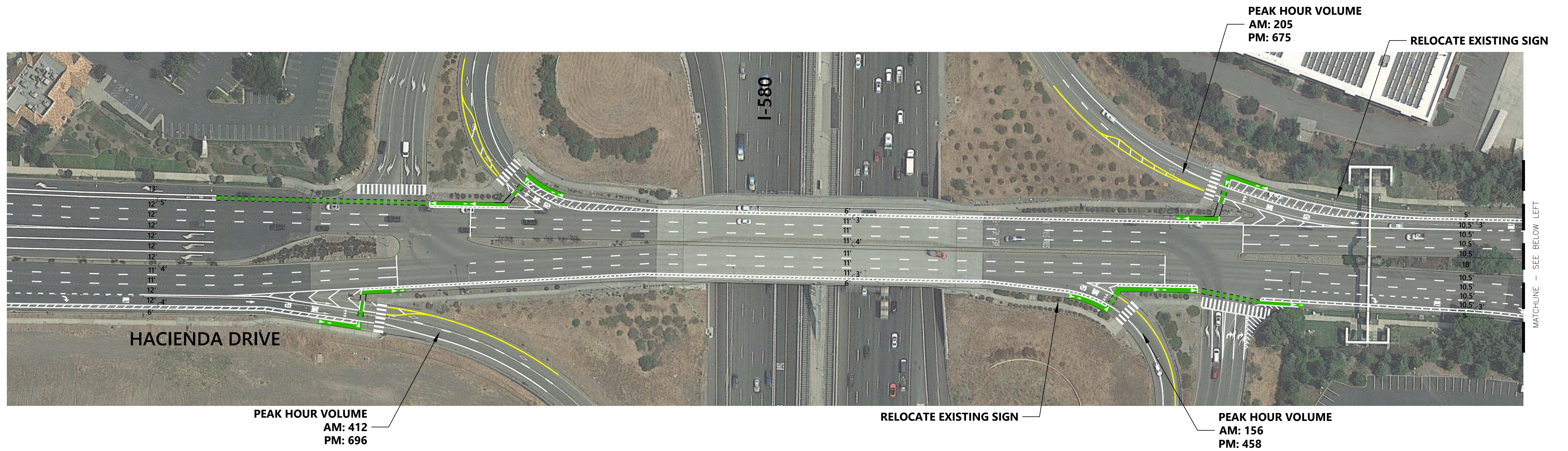

**LEGEND**

- EXISTING CURB
- PROPOSED CURB
- PROPOSED WHITE STRIPING
- PROPOSED YELLOW STRIPING
- GREEN BIKE PAINT
- 42" CHANNELIZER

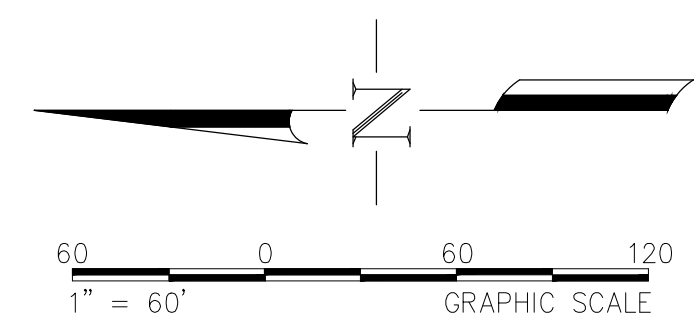
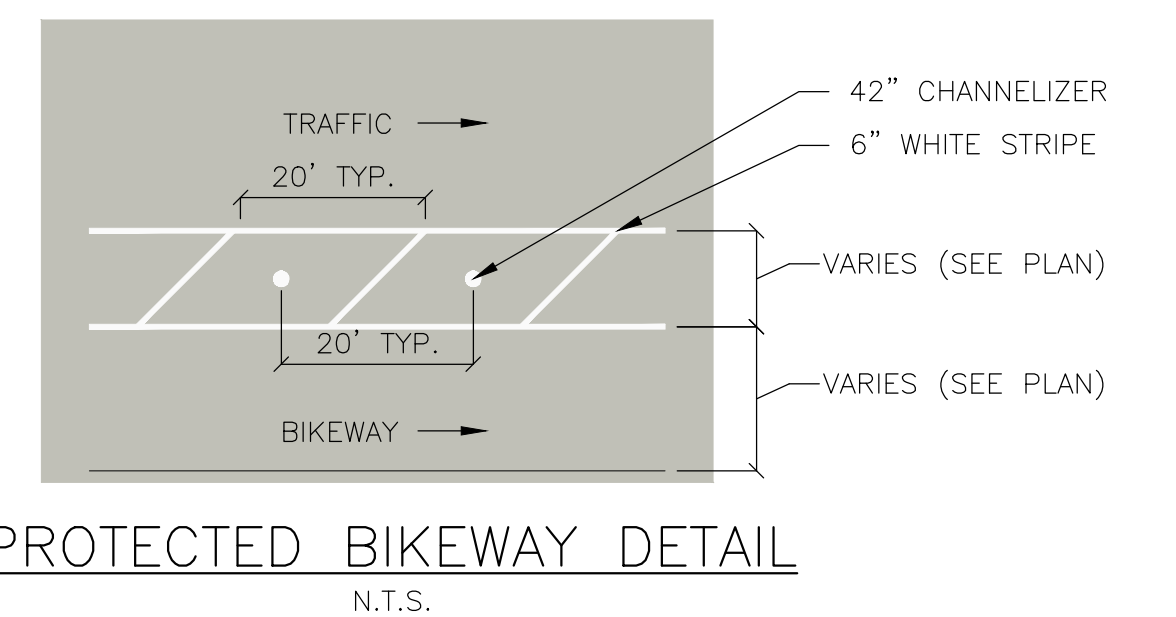

CONCEPTUAL - NOT FOR CONSTRUCTION  
DETAILED ANALYSIS AND ENGINEERING DESIGN REQUIRED

Figure 2  
Hacienda Drive and I-580

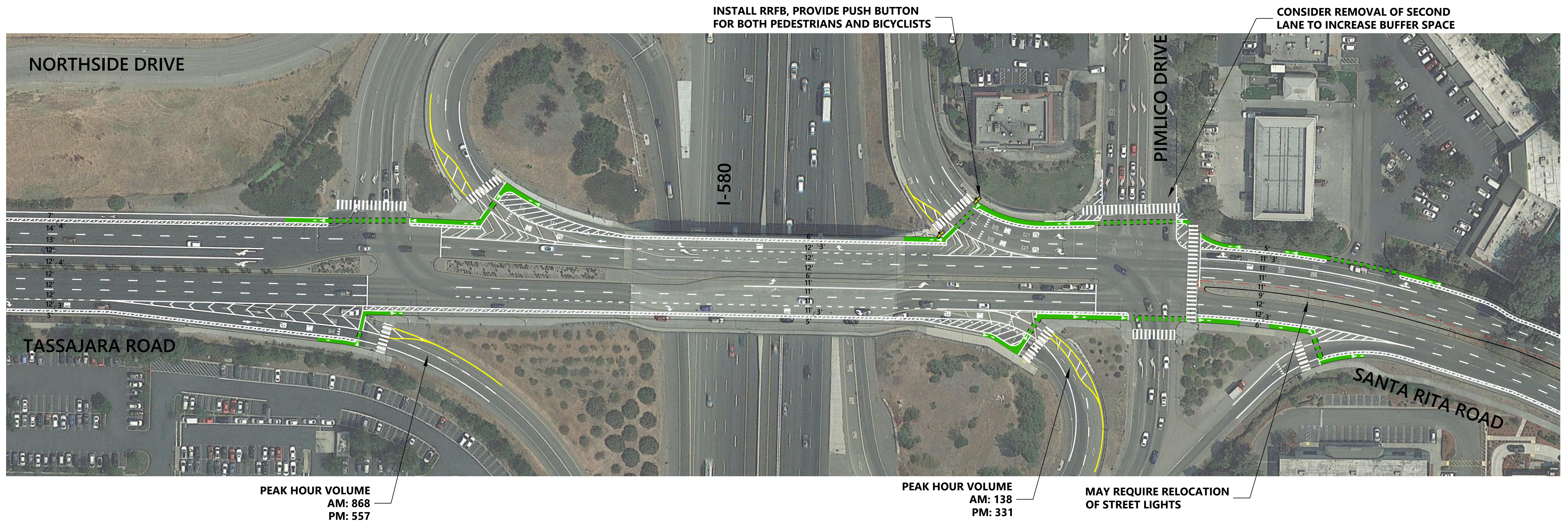

**LEGEND**

- EXISTING CURB
- PROPOSED CURB
- PROPOSED WHITE STRIPING
- PROPOSED YELLOW STRIPING
- GREEN BIKE PAINT
- 42" CHANNELIZER

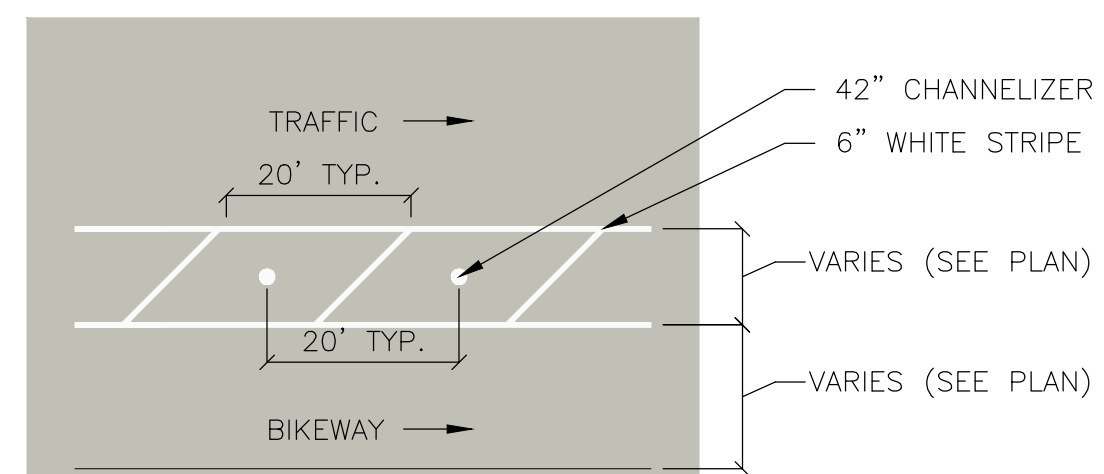

**PROTECTED BIKEWAY DETAIL**  
 N.T.S.



CONCEPTUAL - NOT FOR CONSTRUCTION  
 DETAILED ANALYSIS AND ENGINEERING DESIGN REQUIRED

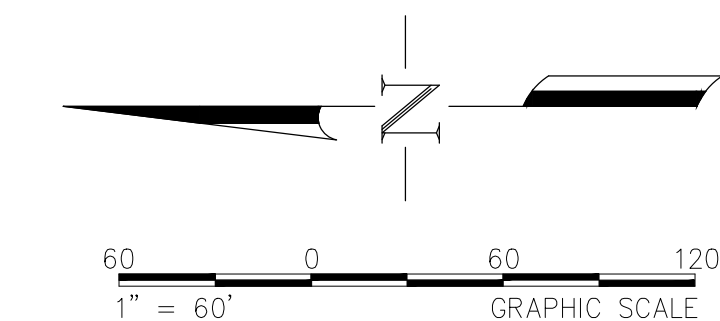

Figure 3  
 Santa Rita Road and I-580